



TRANSFORMERS ENERGY LOSSES

Egamov.D.

Andijan machine building institute

Abdukadirov Akhmadillo Abdukholiq o'g'li

" Energy economy and Energoaudit " course

3rd year Group K95-21

Student of Andijan Institute of Mechanical Engineering

@ahmadilloabduqodirov742@gmail.com

Keywords: Power loss, ferromagnetic core, hysteresis and eddy current losses, efficiency, rated currents, magnetic induction and variable currents, iron core, laminated cores.

Abstract

This article provides information on the analysis and reduction methods of losses in transformers. The losses in electrical machines are calculated based on power losses, the thermal effect of currents, and the change in magnetic flux. In transformers, however, losses depend on the design of the magnetic core and its materials. Anisotropic electrical steel laminations allow reducing energy losses in magnetic cores. The article presents detailed information about the magnetic core part of the transformer and its design.

В этой статье предоставлена информация о методах анализа и снижения потерь в трансформаторах. Потери в электрических машинах рассчитываются на основе потерь мощности, теплового воздействия токов и изменения магнитного потока. В трансформаторах потери зависят от конструкции магнитного сердечника и его материалов. Анизотропные ламинированные стали для электротехнических целей позволяют снизить энергетические потери в магнитных сердечниках. В статье представлена подробная информация о части магнитного сердечника трансформатора и его конструкции.

Bu maqolada transformatorlardagi isrofning tahlili va kamaytirish usullari to'g'risida ma'lumot berilgan. Elektr mashinalardagi quvvat isroflari, tokning issiqlik ta'siri va magnit oqimining o'zgarishiga bog'liq hisoblanadi. Transformatorlarda esa, isrof magnit o'tkazgichning qurilishi va uning materiallari bilan bog'liqdir. Anizotropni elektrotexnik po'lat plastinalari bilan qoplangan magnit o'tkazgichlar



energiya isroflarini kamaytirishga imkon beradi. Maqolada transformatorning magnit o'tkazgich qismi va uning qurilishi tafsilotli ko'rsatilgan.

Main Part

Like in any electrical machines, transformers also have a portion of energy loss inherent within them. These power losses consist of the following:

1. Power loss due to the thermal effect of currents in the winding resistances:

$$P_m = I^2 R_1 + I^2 R_2$$

2. Power loss consumed by hysteresis and eddy currents in the iron core due to the variability of magnetic flux:

$$P_n = P_r + P_v$$

This power loss depends on the material of the iron core, magnetic induction, and the frequency of variable currents.

3. Power loss related to the construction of the transformer (P_k).

Among these, (P_m) and (P_n) are the main losses. Power losses in the windings (P_m) are variable and depend on the load, while losses in the iron core (P_n) are constant during the transformer's operation (within the rated load limit).

The magnetic core of the transformer is a crucial component, responsible not only for enhancing magnetic coupling between windings but also for supporting and anchoring them for structural integrity and stabilization. In order to reduce energy losses generated due to eddy currents (at a frequency of ($f = 50$) Hz) in variable flux, the magnetic cores of transformers are assembled with cold-rolled anisotropic electrical steel laminations, typically with a thickness of 0.35 mm to 0.30 mm, coated with special lacquer and oxide layers for insulation. This laminating process enables increasing the induction in the magnetic core up to 1.6 to 1.65 T (which would not be feasible in hot-rolled steel, where the induction could not exceed 1.4 to 1.45 T), thereby reducing the mass of the transformer's active (magnetic and electric conducting) materials and sharply decreasing energy losses.

The part of the magnetic system where laminations are assembled is called "stator," while the part forming a closed magnetic circuit, thereby enhancing



magnetic flux, is called "rotor." These are the magnetic cores of three-phase transformers. In a three-phase system, the magnetic core of the transformer is modified to accommodate the three-phase flux and loadings. If it is possible to modify the laminations of a single-phase transformer structurally to form a single common core, then it's possible for a three-phase system as well. Since the sum of sinusoidal magnetic flux densities over one cycle is not zero in the general core, it's unnecessary to provide a gap in this core. To simplify this construction, three stators can be placed together and connected with upper and lower rotors, forming a flat-shaped three-phase magnetic core. If all laminations and rotors are aligned in one plane, the magnetic core of the transformer is flat-shaped; if they are arranged in different planes, it's called a stepped core. Depending on the combination of laminations and rotors, magnetic systems are divided into stator-rotor, core-stator-rotor, and armored types.

Transformer (TM— 250/6) phase-shaped magnetic core components: 1- stator, 2 and 6 - insulating spacers; 3- Three-phase plate, 4- rotor; 5- coil; 7- pin; 8- insulating signaling tube; 9- clamping clamp; 10- base plate.

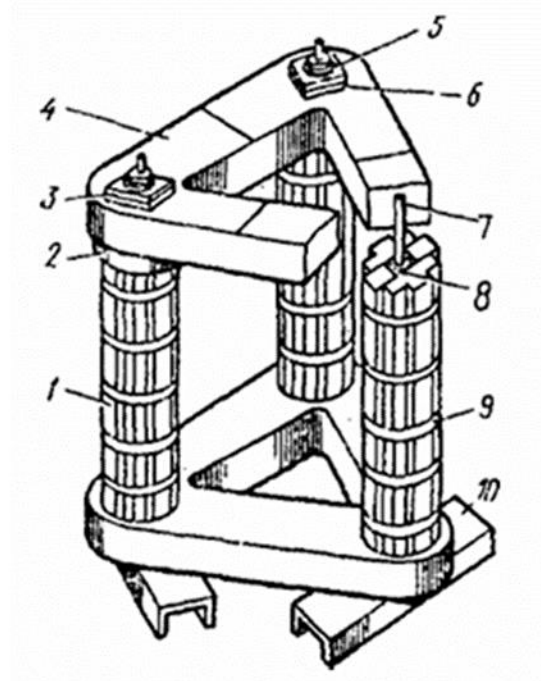

Wastes in the steady-state mode of operation:

Even if the sinusoidal voltage $[u_1=U_{(1)\max}\cdot\sin\omega t]$ is applied to the ferromagnetic core of the transformer and causes the magnetic flux $[\Phi_1=\Phi_{(1)\max}\cdot\sin\omega t]$ to vary sinusoidally, the magnetization characteristic of the ferromagnetic core becomes



nonlinear due to saturation of the magnetic core. As a result, the variation of the magnetizing current $I_{0,r}$ over time $I_{0,r} \cdot f$ (wt) is not sinusoidal.

The steady-state experiment is conducted with no load applied to the secondary winding ($I_2 = 0$). A sinusoidal voltage U_1 is applied to one winding, varying from 0 to 1.2 times $U_{1,N}$. The voltage U_1 , current I_0 , and steady-state power P_0 are measured during the steady-state operation, from which the power factor $\cos\phi_0$ is primarily calculated.

Based on the data obtained and calculated from the experiment, the relationships $I_0 = f(U_1)$, $P_0 = f(U_1)$, and $\cos\phi_0 = f(U_1)$ are referred to as the steady-state characteristics of the operation.

Power rating: $S_N = 100 \text{ kV}\cdot\text{A}$;
Ratio of primary to secondary voltage: $U_{1N}/U_{2N} = 6.3/0.22 \text{ kV}$; Y/Y-connected windings, three-phase transformer, conduct the no-load test; Circuit diagram of the no-load test (a) and no-load characteristics (b); KR - power factor at rated load.

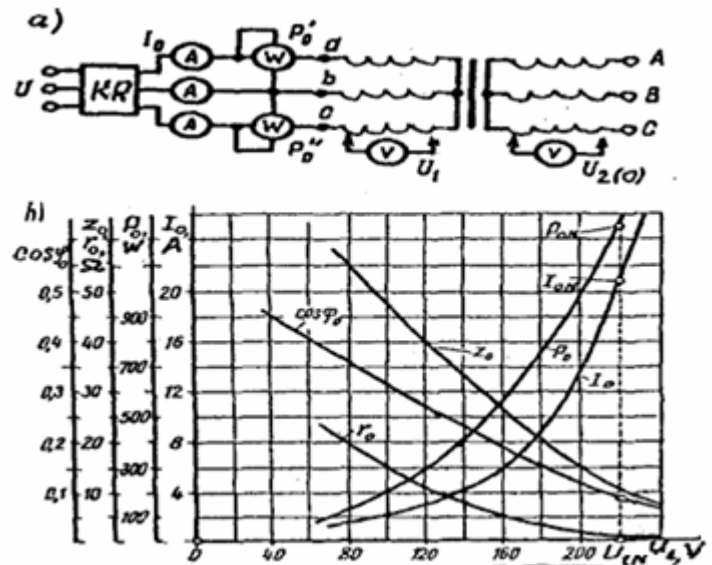

In a three-phase transformer, the values of U_1 and I_0 are measured separately for each phase, and their characteristics are established based on their average values. The mutual agreement between the phases in the transformer where they are located in separate cores is not uniform because the magnetic flux density in the middle phase is intermediate, compared to the flux densities in the outer phases. Consequently, the MYK and the current $I_{0,v}$ in the middle phase are lower compared to those in the outer phases ($I_{0,B} < I_{0,A} = I_{0,C}$).

$I_0 = f(U_1)$. The increase in the applied voltage U_1 leads to an increase in its magnetic flux Φ because $U_1 = E_1 = 4.44f w_1 \Phi_{max}$. At low values of excitation, the magnetic circuit remains unexcited, and the I_0 current changes linearly. Starting from the values $U_1 = (0,5 + 0,6)U_{1N}$, the excitation starts to saturate, reducing the



reactance Z_0 , the leakage reactance x_0 , and the resistance $r_0 = r_m$ correspondingly. As a result, the reactive component I_{0r} of the excitation current increases rapidly concerning the applied voltage U_1 .

The excitation current I_0 consists of reactive (I_{0r}) and active (I_{0a}) components: $I_{0r} = I_{0a} + I_{0x}$. Typically, for power transformers, $I_0 < 0.08 I_{1N}$, with its active component I_{0a} constituting approximately 10% to 0.5% of I_0 . As the nominal power of power transformers increases, the percentage of I_0 relative to the nominal current tends to decrease.

$P_0 = f(U_1)$. In transformers operating under no-load conditions, the power losses in the core due to hysteresis and eddy currents, neglecting the losses due to the primary winding resistance, are considered. These losses in the core depend on B^2 and approximately on the square of the frequency. When $U_1 = \text{const}$ and $f = \text{const}$, the dependency of the core losses on the applied voltage and frequency can be approximately expressed as $P_m = P_0 = \text{const}$.

In modern power transformers with a power of 10+1000000 kV.A, even if the no-load losses are about 1.5% to 0.05% of the rated load losses, they significantly affect the useful work coefficient due to seasonal loading, as the no-load characteristics depend not on the load value but on the transformer's connection to the network through U_{21} .

In the no-load test, important parameters such as the no-load current (I_{0N}) and losses (P_{0N}) are standardized with respect to the rated voltage U_{1N} .

$\cos\phi_0 = f(U_1)$. The power factor $\cos\phi_0$ for a three-phase transformer is determined by the following formula:

$$\cos\phi_0 = \frac{P_0}{\sqrt{3}U_1I_0}$$

where P_0 is the active power of the three phases in watts.

During no-load operation, as the excitation increases, the reactive component I_{0r} of the excitation current increases faster relative to the applied voltage, while the active component I_{0a} decreases. Consequently, due to the increase in the angle ϕ_0 between the U_1 and I_0 vectors, $\cos\phi_0$ decreases.

Important parameters for the transformer are determined based on the values at U_{1N} obtained from no-load experiments:



1) Transformation coefficient $k = U_{1N}/U_{20}$, where U_{1N} is the nominal voltage of the YK winding; U_{20} is the no-load voltage corresponding to the PK winding voltage at U_{1N} ;

2) No-load losses R'_0 ;

3) The value of the no-load current $i_0\% \frac{I_0}{I_{1N}} * 100$;

4) The reactive resistance of the magnetizing circuit r_0 . When the primary circuit's reactive resistance r_2 is several hundred times smaller than the calculated reactive resistance r_m of the magnetizing circuit ($r_m > r_1$), r_1 is assumed to be negligible ($r_1 = 0$), and thus $r_0 = r_m$.

Connection diagram for transformer no-load operation mode.

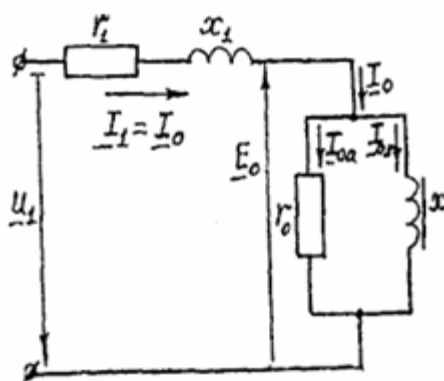

Scientific leader : " Alternate department of energy head teacher Egamov D.A

Literature.

1. Umar IBROHIMOV ELEKTR MASHINALARI Kasb-hunar kollejlari uchun Qayta ishlangan va to'ldirilgan nashri Toshkent «Ukituvchi», «Ziyo Noshir» KShK, 2001

2. Alijanov D.D., Topvoldiyev N.A. (2021). SOLAR TRACKER SYSTEM USING ARDUINO. Theoretical & Applied Science, 249-253.

3. Alijanov D.D., Topvoldiyev N.A. (2022). PHYSICAL AND TECHNICAL FUNDAMENTALS OF PHOTOELECTRIC SOLAR PANELS ENERGY. Theoretical & Applied Science, 501-505.

4. . Эгамов, Дилмурод Абдураимович; Нурёгдиев, Мумаматюсуф Маматкаримович ,ПОВЫШЕНИЕ НАДЁЖНОСТИ ЭЛЕКТРОСНАБЖЕНИЯ В МЕСТАХ ПРОВЕДЕНИЯ ОСОБО ВАЖНЫХ



МЕРОПРИЯТИЙ, Инженерные решения, 8, 4-6, 2019, Общество с ограниченной ответственностью «Грани науки»

5. Эгамов, Дилмурод Абдураимович; Узаков, Рахмонжон; Бойхонов, Зайлобиддин Уразали; , "Способы обеспечения бесперебойного электроснабжения потребителей, имеющих одну систему шин 6-10 кВ и два независимых источника питания 6-10 кВ", Бюллетень науки и практики, 4,

6. Эгамов, ДА; Узаков, Р; Боихонов, ЗУ; , "Эффективность применения «переносного АВР-0, 4 кВ» для обеспечения бесперебойного электроснабжения потребителей", 2019, ГГТУ им. ПО Сухого

7. Эгамов, Д.А. Собиров.; , РАЗРАБОТКА СТРУКТУРНОЙ СХЕМЫ «МОБИЛЬНОГО АВР 04 КВ

8. Parpiev, Oybek Bakhtiyorjonogli; Egamov, Dilmurod Abduraimovich; , Information on synchronous generators and motors, Asian Journal of Multidimensional Research, 10, 9, 441-445, 2021, TRANS Asian Research Journals

9. Эгамов. Д.; , Гидроэлектр станцияларда ўрнатилган 6-10 кВ ток трансформатори хатоликларига юклама токининг ва иккиламчи занжир юкламасининг салбий таъсири , ЎЗБЕКГИДРОЭНЕРГЕТИКА, 1, IV(8), 23, 2020, ФЕРПИ

10. Abdulhamid o'g'li, T. N., & Botirjon o'g'li, A. M. (2024). FOTOELEKTRIK STANSIYALARNING TIZIMLARINI HISOBLASH TURLARI. *Oriental Journal of Academic and Multidisciplinary Research*, 2(3), 49-54.

11. Abdulhamid o'g'li, T. N., & Botirjon o'g'li, A. M. (2024). FOTOELEKTRIK STANSIYALARDAGI INVERTORLARNI XISOBLASH. *Oriental Journal of Academic and Multidisciplinary Research*, 2(3), 43-48.

12. Abdulhamid ogli, T. N., & Axmadaliyev, U. A. (2024). DEVELOPMENT AND APPLICATION OF 3rd GENERATION SOLAR ELEMENTS. *Лучшие интеллектуальные исследования*, 14(2), 219-225.

13. Abdulhamid ogli, T. N., & Azamjon ogli, S. H. (2024). IMPLEMENTATION OF SMALL HYDROPOWER PLANTS IN AGRICULTURE. *Лучшие интеллектуальные исследования*, 14(2), 182-186.

14. Abdulhamid ogli, T. N., & Yuldashboyevich, X. J. (2024). ENERGY-EFFICIENT HIGH-RISE RESIDENTIAL BUILDINGS. *Лучшие интеллектуальные исследования*, 14(2), 93-99.



15. Abdulhamid ogli, T. N., & Yuldashboyevich, X. J. (2024). SOLAR PANEL INSTALLATION REQUIREMENTS AND INSTALLATION PROCESS. *Лучшие интеллектуальные исследования*, 14(2), 40-47.
16. Abdulhamid ogli, T. N., Axmadaliyev, U. A., & Botirjon ogli, A. M. (2024). A GUIDE TO SELECTING INVERTERS AND CONTROLLERS FOR SOLAR ENERGY DEVICES. *Лучшие интеллектуальные исследования*, 14(2), 142-148.
17. Topvoldiyev, N. (2023). KREMNIY ASOSIDAGI QUYOSH ELEMENTILARI KONSTRUKTSIYASI. *Interpretation and researches*, 1(1).
18. Abdulhamid o'g'li, T. N., & Sharipov, M. Z. (2023). ENERGY DEVELOPMENT PROCESSES IN UZBEKISTAN. *Science Promotion*, 1 (1), 177–179.
19. Topvoldiyev, N. (2023). Storage of Electricity Produced by Photovoltaic Systems.
20. Alijanov, D. D. (2023). Storage of Electricity Produced by Photovoltaic Systems.
21. Abdulhamid o'g'li, T. N. (2022). Stirling Engine and Principle of Operation. *Global Scientific Review*, 4, 9-13.
22. Abdulhamid o'g'li, T. N., & Muhtorovich, K. M. (2022). Stirling's Engine. *Texas Journal of Multidisciplinary Studies*, 9, 95-97.
23. Topvoldiyev, N. (2021). SOLAR TRACKER SYSTEM USING ARDUINO. *Scienceweb academic papers collection*.