

DESIGNER SYSTEM FOR DESIGNING RADIO-ELECTRONIC DEVICES AND THEIR ELEMENTS

*M.Kh.Aripova,
B.B. Ibragimova (TSTU)*

The article discusses the possibility of using modern Altium Designer system for the design of electronic devices and their components.

Keywords: radio electronics, design, e-library, radio components, automated programs, printed circuit board, trace, line-up.

The need to design complex radio-electronic equipment (RES) and the requirements for reducing their design time and increasing the quality of design work requires the use of computer technology in the design process. In this regard, automated methods for designing radio electronic devices are widely introduced into the practice of the radio industry.

A radio-electronic device is understood as a product or its components, the functioning of which is based on the principles of radio engineering and electronics. There are different levels of disaggregation of RES, these are radio-electronic systems, complexes, devices and functional units. The operation of the RES is based on the transmission, extraction and processing of information, as well as the conversion of electromagnetic energy.

Individual radio electronic devices or functional units can form a class of enlarged basic elements that largely determine the characteristics of complex systems and complexes. Basic elements include digital and analog signal generation and processing units, amplifiers, radiating devices, various filters, frequency separating, matching devices, etc. A significant part of them operate in the radio frequency range and form the basis for constructing radio frequency paths of systems and complexes .

Radioelectronic equipment can be a very complex technical object, including a large number of components and diverse connections between them.

very diverse in terms of the content and sequence of tasks to be solved, depending on the functional and design complexity of the radio engineering systems, complexes, devices and assemblies being developed. In this regard, to automate the design of electronic distribution systems and their functional units and elements, a lot of computer-aided design (CAD) systems have currently been developed. Altium system Designer is one of the modern automation systems for the design of electronic systems. It includes the following main modules:

- DXP shell (abbreviation for Design eXPlorer), which combines the components of the development (electrical diagram, printed circuit board design, description of VHDL logic) into a single whole - the project;

- electrical circuit editor;

- PCB editor with automatic element placement and routing tools;

- circuit modeling tools PSpice and XSPICE ;

- modeling, development and debugging tools programmable logic integrated circuits (FPGAs) based on VHDL - opsanii (VHSIC-Very high speed integrated circuits, Hardware Description Language) - language descriptions equipment integral schemes .;

- tools for modeling, development and debugging of FPGAs based on a library of logical components without using VHDL ;

- electrical circuit analysis tools;

- means of preparing the mounting field of the printed circuit board, determining the structure of the layers, rules for performing printed wiring;

- Signal tools Integrity , which allows you to simulate the mutual influence of components, types of routing, parasitic effects, etc.;

- means of implementing the JTAG interface;

- means of generating control information for production equipment.

Besides Altium Designer contains a number of other tools related to the development of electronic systems. For a complete “end-to-end” cycle for the development of electronic devices, the only things missing are the parts that provide firmware for FPGAs, microcontrollers and other programmable chips, as well as the automatic creation of a complete set (drawings, specifications, etc.) of design documentation in accordance with GOST.

Altium system Designer includes tools for all design tasks: from schematic and design HDL collection, circuit simulation, signal integrity analysis, PCB design, and FPGA-based systems engineering and design (Figure 1). In addition, the Altium Developer Environment can be customized to meet a wide range of customer requirements.

As part of Altium Designer comes with many element libraries that contain most of the common elements - resistors, capacitors, transistors , microcircuits, etc. In addition to the conventional graphic designation, they contain mathematical models for simulating 3 D models for the PCB editor, as well as a link to the site manufacturer and technical description, which can be downloaded if you have an Internet connection.

On Altium systems Designer, you can activate any menu by pressing the accelerator key (“Hot” key) (the underlined letter in the menu name). There are also hotkeys for nested menu items . For example, to select from a menu

" View " Fit Document (View Entire Document) , you can press the V key and then the D key. In addition, many submenus, such as Edit DeSelect , can be accessed directly. For example, to call the command " Edit " " DeSelect " All on Current Document (" Edit" "Deselect" Everything in the current document), you must press the X key (to directly bring up the DeSelect menu) and then press the S key.

Altium Project Designer contains project-related options and links to all documents. The project file (type xxx.PrjPCB) is an ASCII text file that lists the documents used in the project and the parameters for generating output data, for example, for printing or transferring to manufacturing management systems (CAM). Documents that are not associated with any project are called free documents . documents). References to schematic sheets and target outputs, such as PCB, FPGA, embedded (VHDL), or library packages, are added to the project. Once the project is compiled, you can perform operations such as project verification, synchronization, and comparison. For example, compilation updates the design with any changes made to the original circuit diagram or PCB.

The process of creating a project does not depend on its type. For example, to create a printed circuit board project, first create a project file , for this, select " New " " Project " PCB Project from the File menu or click Blank Project (PCB) in the New section of the Files panel . If the panel is not visible, click the System button * in the lower right corner of the main window and select * Files . The Projects panel opens and displays the new project file PCB_Project1.PrjPCB (without any documents added). The project file is then renamed (with the extension . PrjPCB). To do this , select from the File menu Save Project As (Save project as...). Save the file and then add a blank sheet to it to create the circuit diagram. To create a schematic sheet, follow these steps: Right-click the project file in the Projects panel and select Add New to Project » Schematic (Add a new Schematic Diagram document to the project). A blank sheet of schematic diagram named Sheet1.SchDoc opens in the main window, and in the Projects panel in the Source directory Documents The icon for the diagram associated with the project appears. The new diagram is saved (with the extension . SchDoc) by selecting File » Save from the menu As (File » Save As). Go to the folder on your hard drive where you want to save the diagram in the File field Name * Enter a name for the file.SchDoc and click the * Save button .

Having opened a blank sheet of the circuit diagram, we notice that the working environment has changed. New buttons have appeared on the main toolbar, new toolbars have become available, new items have appeared in the menu bar, and a Sheet panel has appeared . This is a circuit diagram editor. Here you can customize many elements of the workspace to suit your requirements. For example, you can change the layout and customize the contents of toolbars and menus.

Let's consider an example for constructing a circuit diagram of an unsynchronized multivibrator, which uses two 2N3904 transistors (Fig. 2).

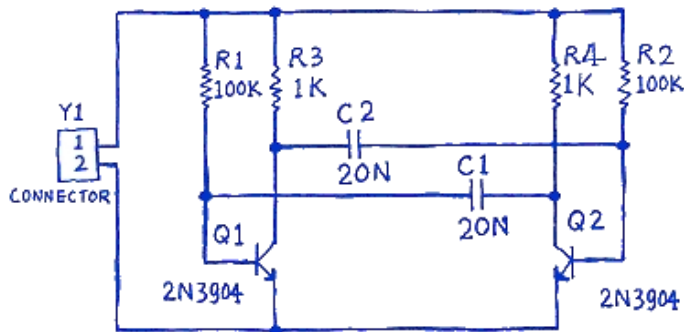

Fig. 2 Multivibrator circuit.

To manage the thousands of graphical symbols included in Altium Designer , provides powerful library search capabilities.

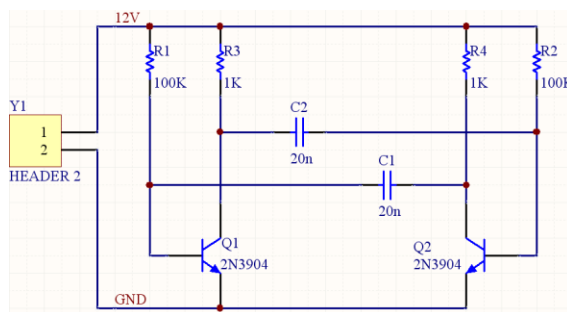

Fig.3. Connected circuit components.

Finding from libraries various components for multiselector circuits , putting electrical connections between the circuit elements in accordance with the circuit sketch, we obtain the circuit shown in Figure 3. The system has all the capabilities for users to design radio electronics, simulate electrical circuits, conduct parametric analysis of elements, develop a printed circuit board electronic devices. The system allows you to create multi-channel and multi-variant projects, design rigid-flex printed circuit boards and place hidden components on the internal layers of the printed circuit board.

Literatures

1. Alexey Pavlovich Borisov. Altium Designer . Quick guide. Samizdat, Textbook, 2021.
2. Vladislav Sukhodolsky: Altium Designer . End-to-end design of functional units of electronic distribution systems on printed circuit boards. Textbook Ed. BHV,2017.